



10  
9  
8  
7

SCOTT

2026 SCOTT  
**ADDICT MANUAL**

# CONTENT

THE ADDICT SHOULD BE ADJUSTED EXACTLY TO THE RIDER FOR MAXIMUM SAFETY AND RIDEABILITY.

Please contact your authorized SCOTT dealer for advice in order to avoid technical problems or any harm.

GEOMETRY & TECHNICAL DATA	03
SEATPOST INSERTION	04
SEATPOST CLAMP	05
ROTOR SIZE	06
CABLE ROUTING OVERVIEW	07
REAR BRAKE CABLE ROUTING	08
FRONT BRAKE CABLE ROUTING	09
SHIMANO DI2 ROUTING	14
SAVE THE DAY KIT	16
GENERAL SPARE PARTS	18
MANUFACTURE'S GUARANTEE	23

# LEGEND



TORQUE AMOUNT



TORX TOOL SIZE



HEX TOOL SIZE



CLEAN SURFACE



GREASE REQUIRED



NO GREASE REQUIRED



CARBON GREASE



THREADLOC REQUIRED



BEARING FIT REQUIRED

# GEOMETRY & TECHNICAL DATA

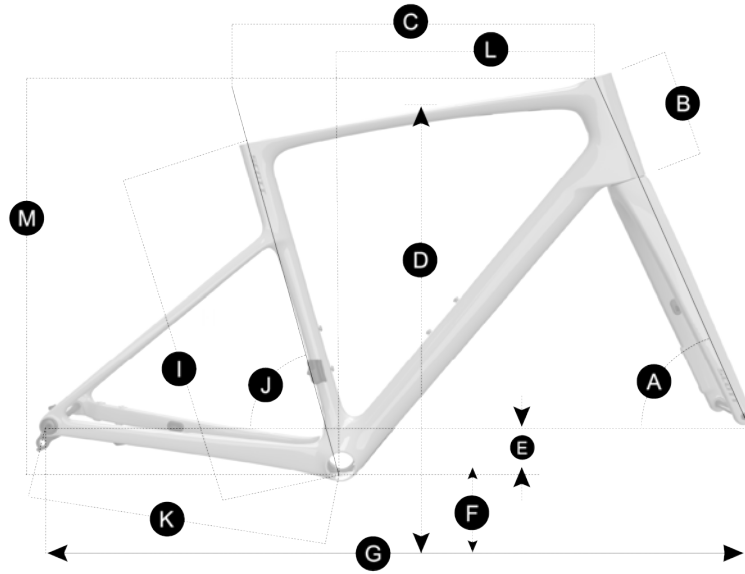

SEATPOST	mm	Addict RC specific	FRONT AXLE	mm	12 x 100
SEATPOST CLAMP	mm	Addict RC specific	MAX TYRE WIDTH	mm	38
FORK STEERER	mm	27.2	BB HOUSING	mm	41 x 86.5
HEADSET	mm	IS44/35 - IS52/42	MAX ROTOR FRONT	mm	180
REAR AXLE	mm	12 x 142	MAX ROTOR REAR	mm	160
MAX CHAIN RING X1	TOOTH	48	MAX CHAIN RING X2	TOOTH	52-36

		47	49	52	54	56	58	61
2026 ADDICT								
A Head tube angle	°	71.3	71.8	72	72.2	72.5	73	73
B Head tube length	mm	104	115	139	161	182	201	221
C Top tube horizontal	mm	511	521	536	551	566	582	597
D Standover height	mm	742	758	780	801	821	840	865
E BB offset	mm	-74	-74	-73	-72	-72	-72	-72
F BB height	mm	275	275	276	277	277	277	277
G Wheelbase	mm	984	991	1000	1009	1016	1022	1036
I BB center to TST	mm	435	455	475	495	515	535	565
J Seat angle	°	75	75	74.5	74	73.5	73.1	73
K Chainstay	mm	418	418	418	418	418	418	418
L Reach	mm	372	378	382	386	389	394	402
M Stack	mm	522	534	557	578	599	619	638
Fork Rake	mm	47	47	47	47	47	47	47
Trail	mm	68.5	65.2	64	62.7	60.8	57.6	57.6

# ADDICT

## MAX SEATPOST INSERTION

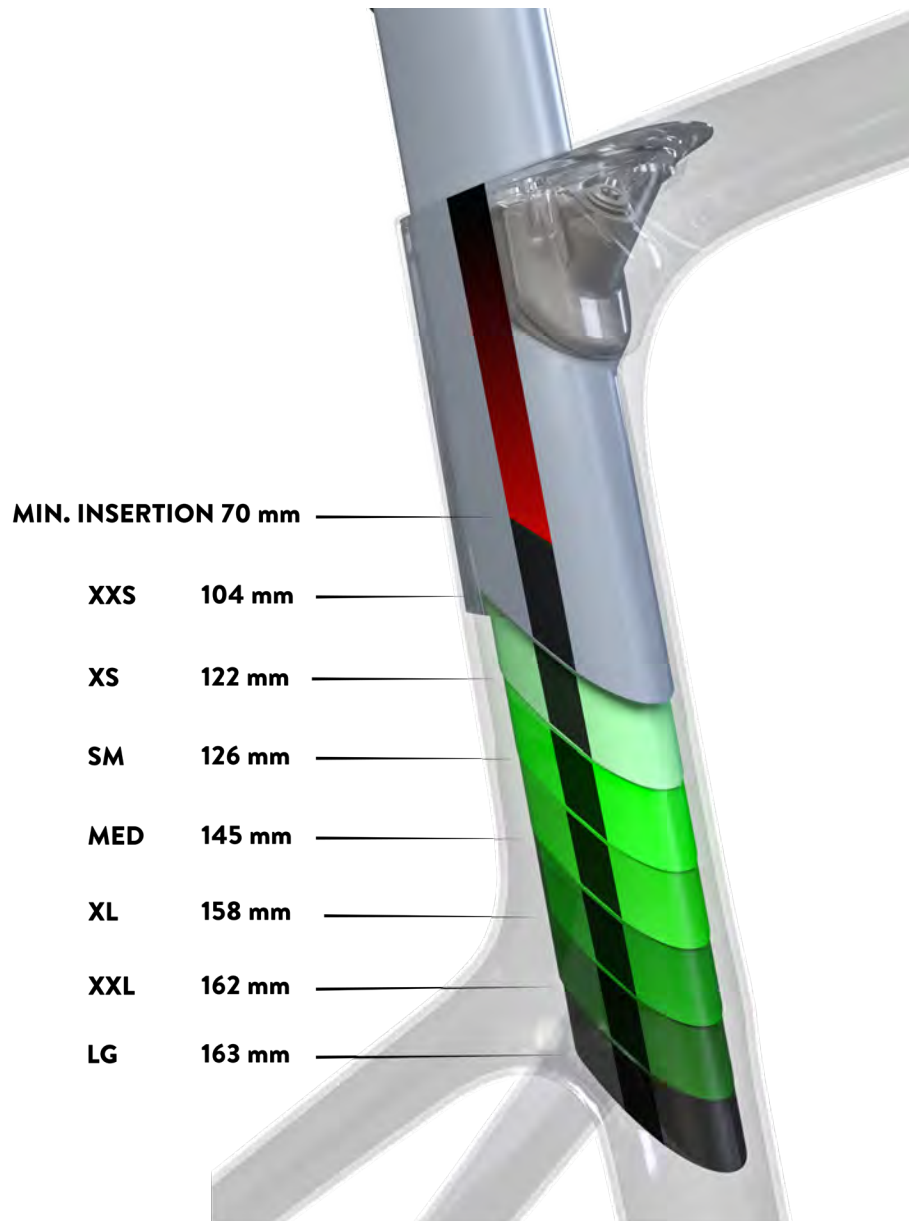

# ADDICT

## SEATPOST CLAMP

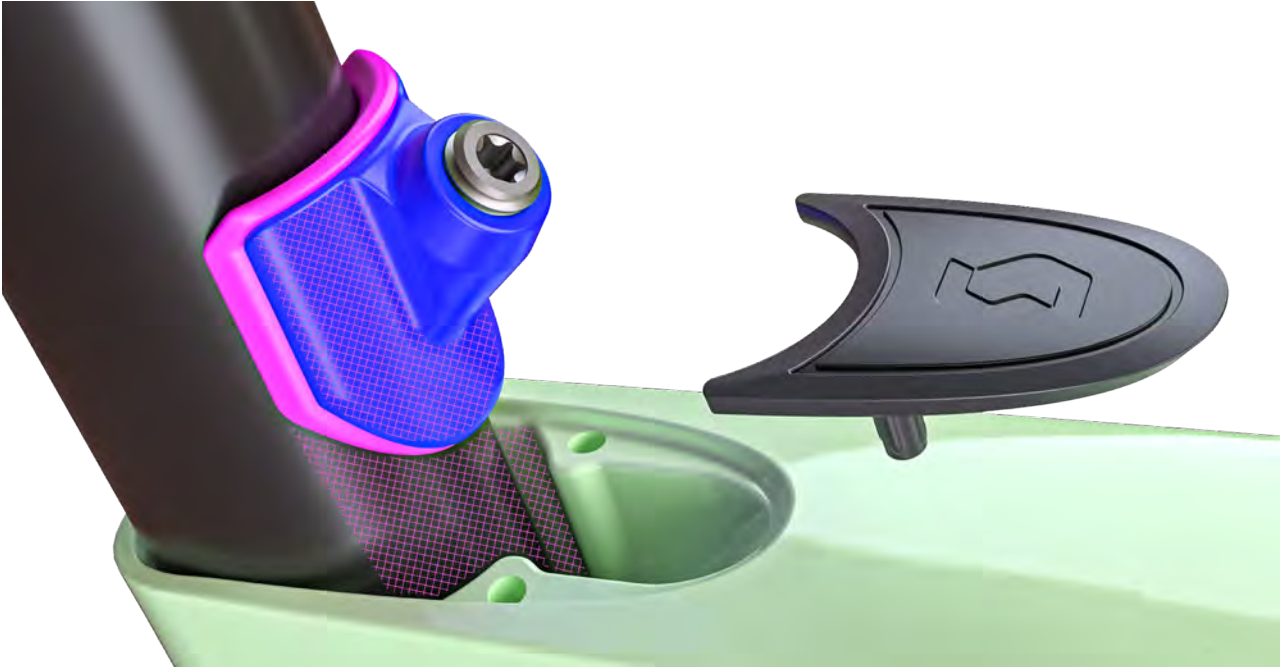

The clamp is one piece and will only be available as a complete unit (spare part section). The profile will incorporate a non slip profile to stop the clamp from sliding down inside the seat tube after the seatpost has been installed.

Use carbon grease where indicated.



# ADDICT

## ROTOR SIZE



Fork brake rotor max. 180mm  
Shimano **Y8N230000** adaptor  
(purple illustration)

Fork brake rotor min. 160mm  
Shimano  
(green dashed illustration)

Sram flat mount adaptor:  
**00.5318.018.000**

\* torque bolts to brake manufacturers recommendation

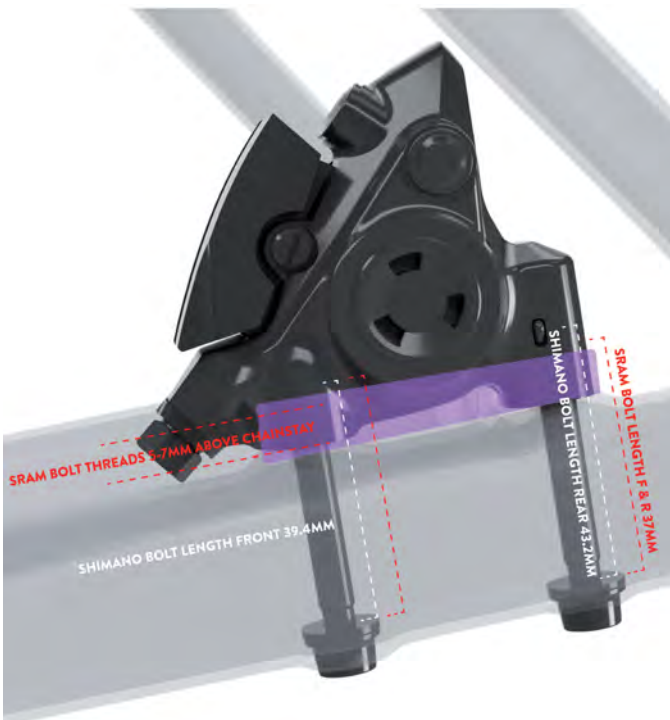

Rear brake rotor min. 140mm  
Shimano / Sram flat mount  
**NO ADAPTOR** directly mounted

Maximum rear brake disc  
160mm Shimano **FLAT MOUNT  
R160D/D (+20mm)**  
(illustration in purple)

Sram 160 flat mount adaptor:  
**00.5318.018.001**

\* torque bolts to brake manufacturers recommendation

\*bolt lengths the same for 140mm & 160mm rotors

# ADDICT

## CABLE ROUTING OVERVIEW



# ADDICT

## REAR BRAKE CABLE ROUTING

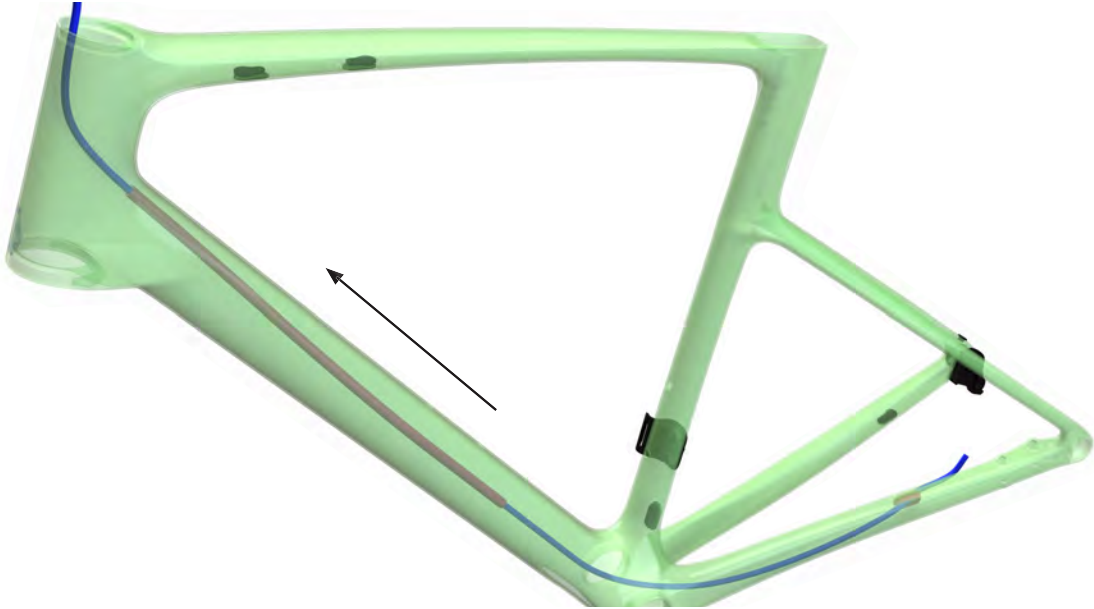

- 01** Guide the rear brake hose from the chainstay entrance through the frame and out the headtube.  
Make sure the anti-rattle foam tubing is in place and **CANNOT** touch the fork steerer.



- 02** Assemble the rear brake.

For 160mm rotors use the adaptors below:  
Shimano 160mm flatmount R160D/D(+20mm)  
SRAM 160mm 00.5318.018.001

\*bolt type and bolt torque follow  
the brake manufacturers  
recommended settings.

\*bolt lengths are the same  
for 140mm & 160mm rotors.

# ADDICT

## FORK BRAKE CABLE ROUTING

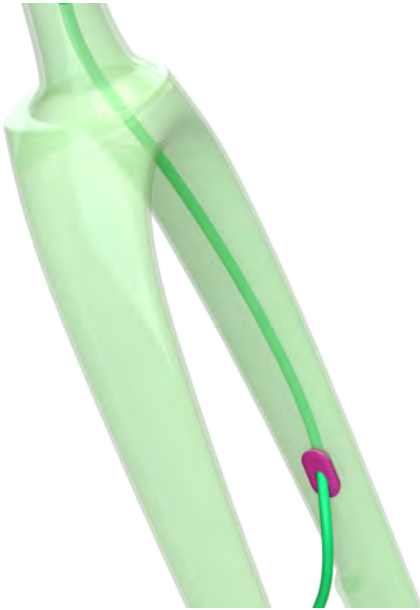

- 01** Fit the fork cable guide and then guide the front brake hose through the fork, exit via the steerer slot. Mount the front caliper by using the preferred adaptor and brake bolts, lightly grease the surface of the fork brake bosses. Apply threadloc to the brake bolts.



- 02** Grease and assemble the lower headset bearing. Tape the brake hose to the fork steerer.



- 03** Guide the rear derailleur cable through the frame, from chainstay to headtube. Make sure the anti-rattle foam tubing is in place and **CANNOT** touch the fork steerer.

# ADDICT

## FORK BRAKE CABLE ROUTING

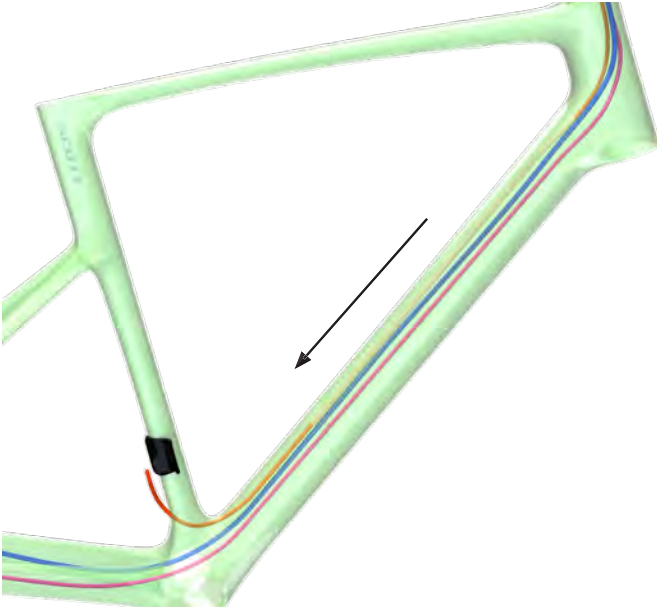

**04** Guide the front derailleurs cable from the top of the headtube to the exit at the base of the seat tube.

Make sure the anti-rattle foam tubing is in place and **CANNOT** touch the fork steerer.

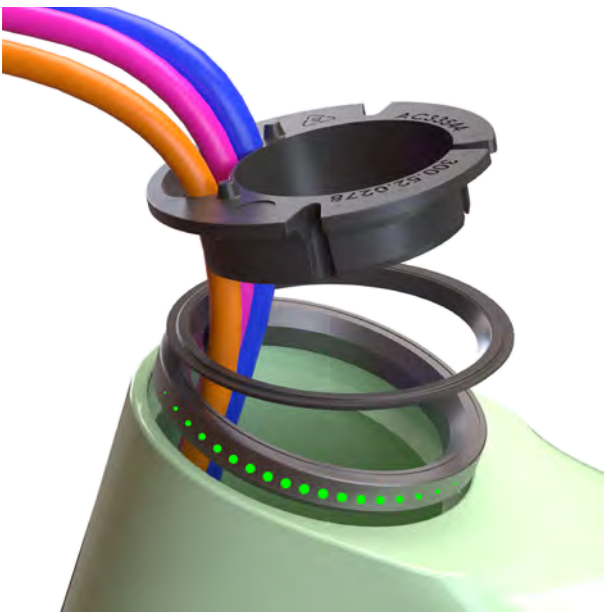

**05** Grease and mount the upper headset bearing, bearing shim, and compression ring.



**06** Assemble the fork. Clean the top of the fork steerer, remove any grease.

# ADDICT

## FORK BRAKE CABLE ROUTING

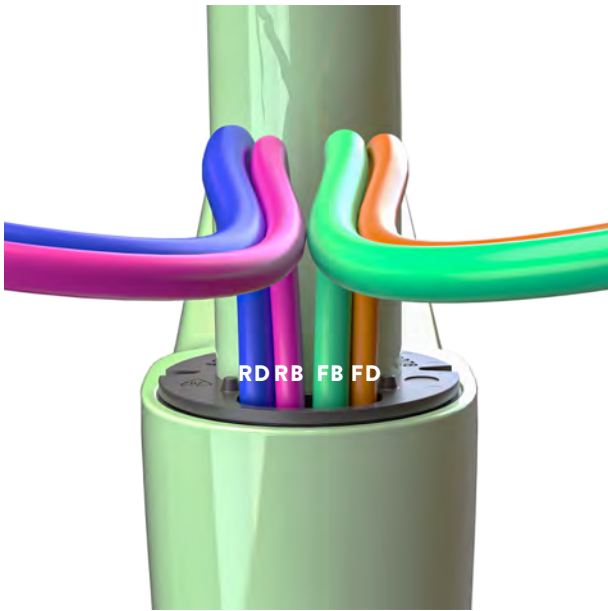

- 07** Guide the front brake hose through the upper headset assembly, making sure all the cables are in the correct position.



- 08** Assemble the headtube cover and spacers.



- 09** Assemble the stem cover, only two turns of the HEX tool. Clean and remove any grease from the stem.



- 10** Then carefully guide the cables and hoses between the stem and cover.

# ADDICT

## FORK BRAKE CABLE ROUTING

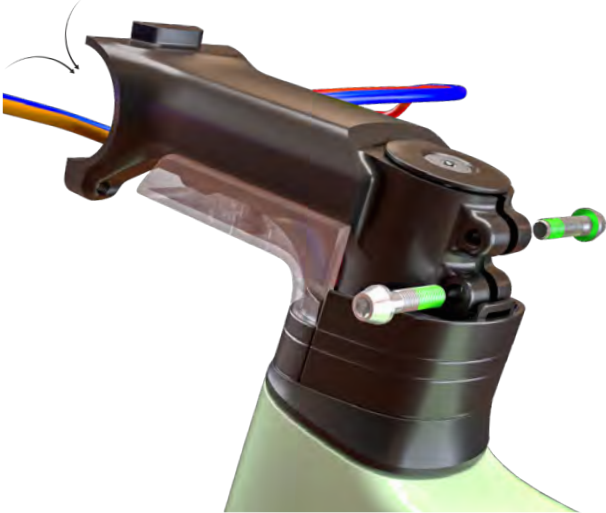

- 11** Assemble the stem to the fork, gently push the cables back into the stem a few centimetres. Do not remove the existing compound from the bolt threads.

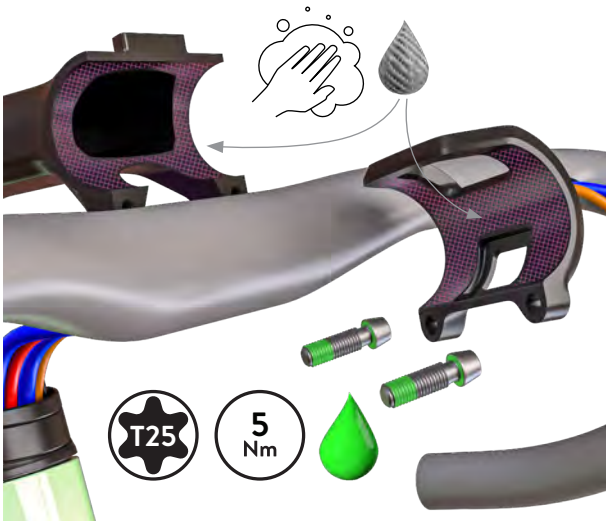

- 13** Guide the cables through the handlebar, starting with the brake hoses. Assemble the stem face plate. Apply grease to the bolts as specified. Clean, then apply carbon grease to the indicated stem interface surfaces.

3MM

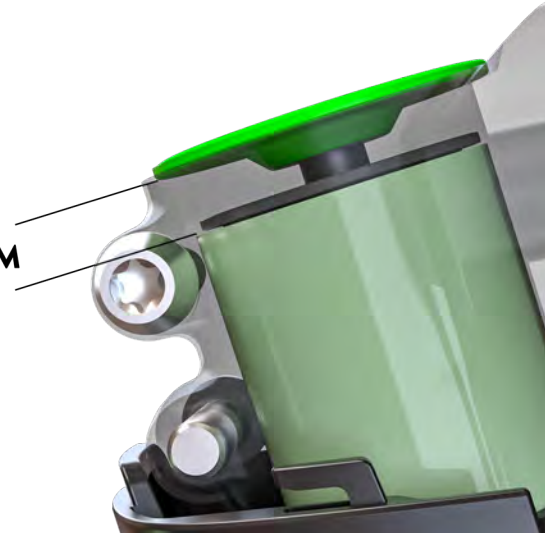

- 12** Ensure that the maximum allowable clearance of 3 mm between the stem and the steerer tube is not exceeded.

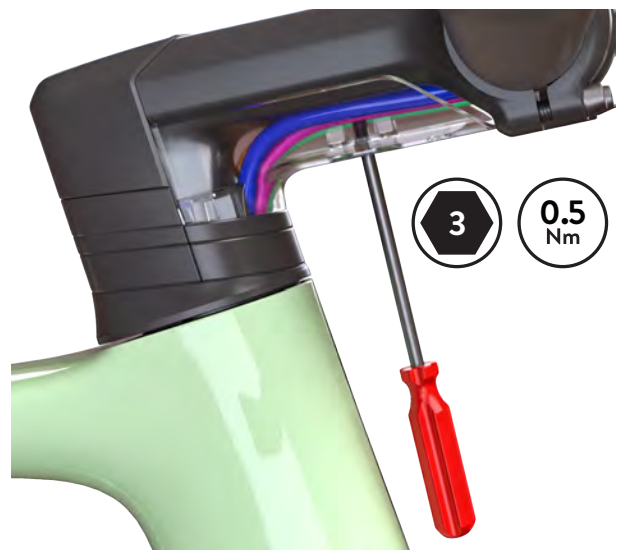

- 14** Once the cables are connected to the levers, push the remaining cable into the headtube and tighten the cable cover.  
Mount the front derailleur and rear derailleur. Tighten to the manufacturer's recommended torque value.

# ADDICT

## FORK BRAKE CABLE ROUTING



- 15** Before assembling the combo handlebar to the fork steerer make sure to clean both surfaces. Do not use grease on either interface.



- 16** The combo handlebar clamp has a max torque of 4Nm.

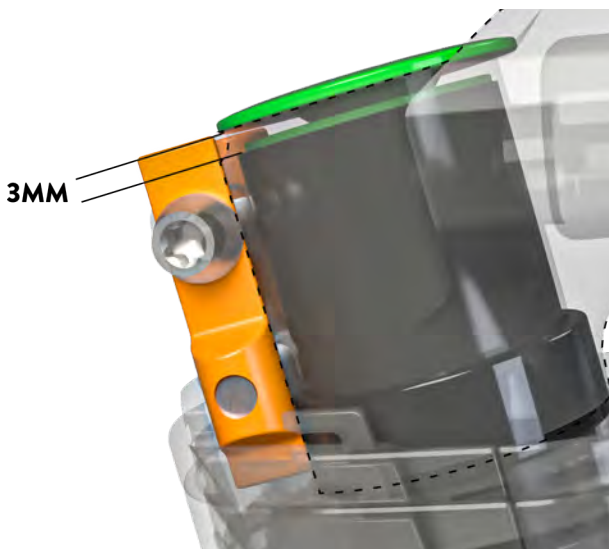

- 17** Ensure that the maximum allowable clearance of 3 mm between the stem and the steerer tube is not exceeded.



- 18** Install the brake/shift level assembly onto the handlebar and tighten to the manufacturer's recommended torque value.

# ADDICT

## SHIMANO Di2 CABLE ROUTING



- 01** Insert the Di2 battery into the rubber sleeve and position into the seatpost as shown.



- 02** For short seatposts/short riders attach the rubber sleeve to the top of the battery and secure with a zip tie and position as shown.



- 03** Attach the front derailleur plate, then the front derailleur. Then guide the Di2 wire through the rubber guide into the seattube.



- 04** Make sure you guide the wire through the cable protection tube, exiting at the top of the seattube.

# ADDICT

## SHIMANO Di2 CABLE ROUTING



**05** Attach to the rear derailleur as shown.



**06** Attach the Di2 wire to the front derailleur first and then guide it into the seat tube. This is maybe easier with the bike upside down.

\*torque FD bolt to FD manufacturers recommendation

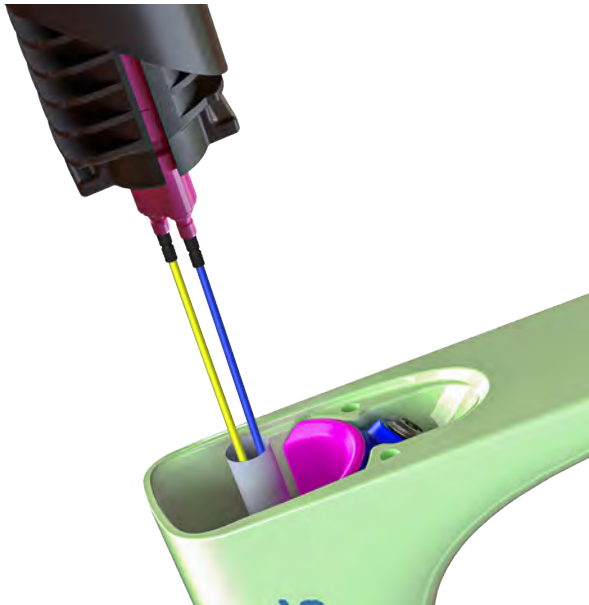

**07** Make sure you guide the wire through the cable protection tube, exiting at the top of the seat tube.

# ADDICT

## SAVE THE DAY KIT

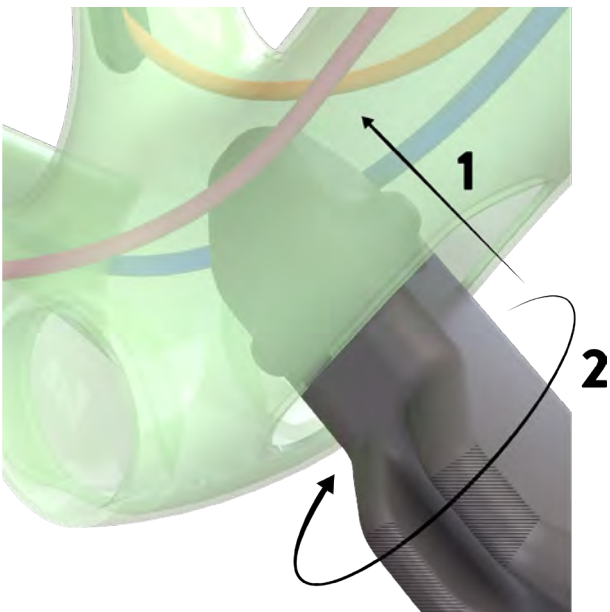
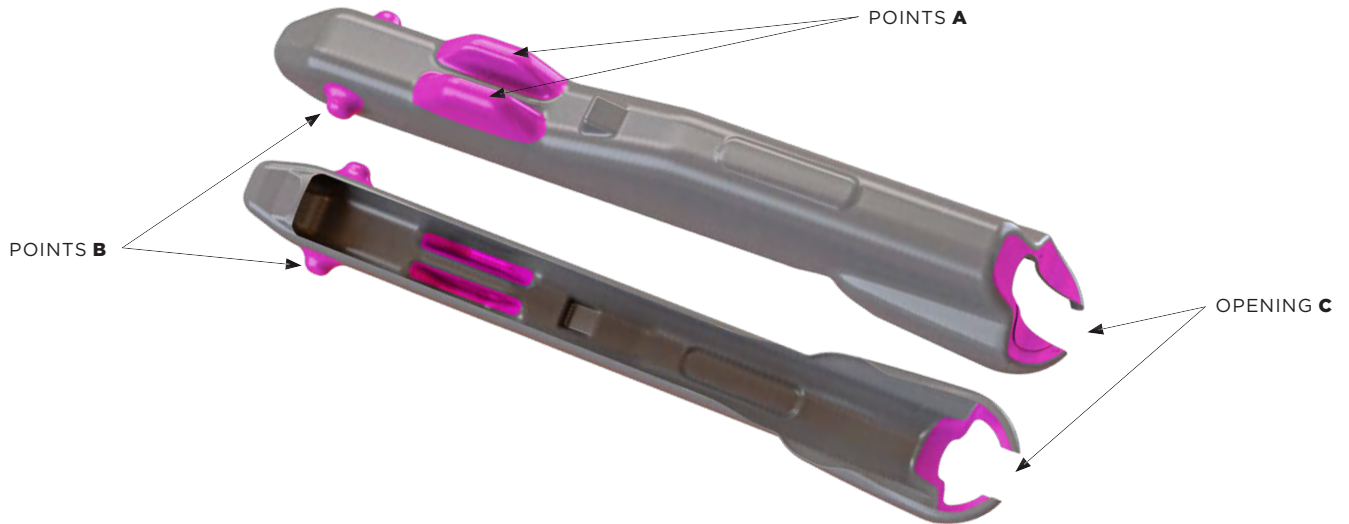

- 01** **Step 1:** Enter the frame with the container vertical to the downtube. Points **B** should be at 12 o'clock and 6 o'clock.
- Step 2:** Rotate the container 90° counter clockwise. Points **A** should face the ground.

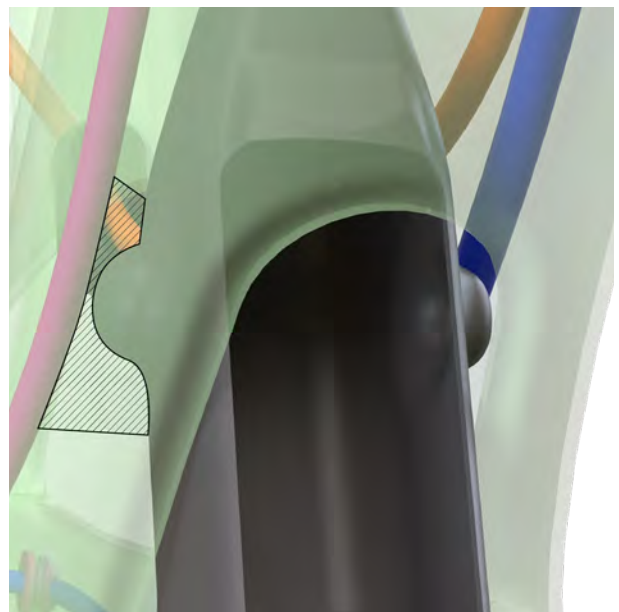

- 02** Make sure the cables are above Points **B**.

# ADDICT

## SAVE THE DAY KIT

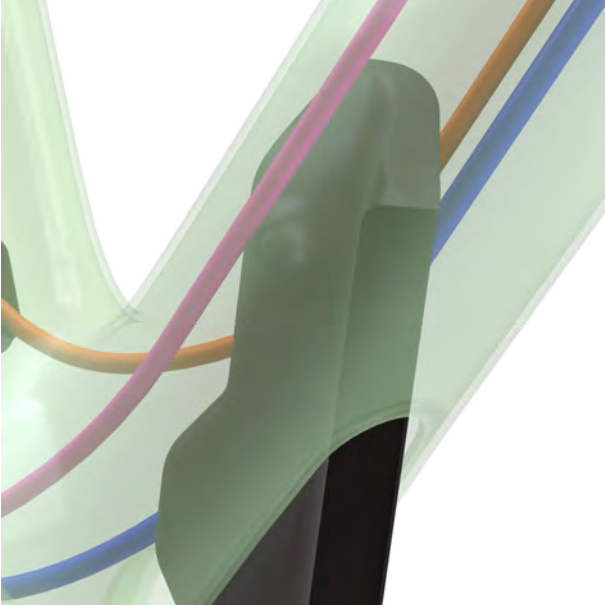

- 03** Carefully push the container into the downtube keeping the cables above. You may have to squeeze the container a little to work it in evenly.

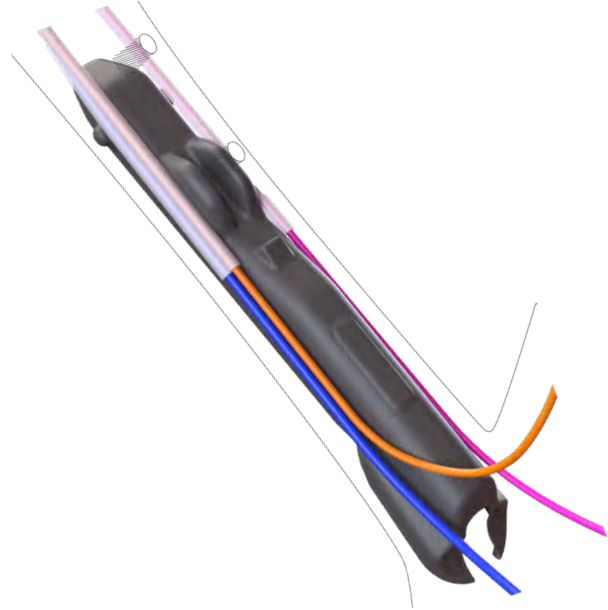

- 04** Once the container has reach its final position, Points **A** should be either side of the bottle bolt bases. Opening **C** should be placed neatly in the frame opening.



- 05** Attach the cover, making sure the lock dial is in a vertical position.

# ADDICT

## GENERAL SPARE PARTS



426248 SCO DROPOUT SHIMANO DM UDH 26



Reverse Thread !



286000 SCO DROPOUT SRAM UDH 21



Reverse Thread !



426247 SCO REAR AXLE TP ADDICT|FASTLANE 26



424160 SCO AXLE ADDICT RC F 25



424158 SCO SEATPOST CLAMP ADDICT RC 25



# ADDICT

## GENERAL SPARE PARTS



424156 SCO HEADSET EXPANDER ADDICT RC 25



424154 SCO STEM SPACER|TOP CAP KIT ADDICT RC 25



426256 SCO HEADTUBE COVER ADDICT 26



426253 SCO STEM CABLE COVER ADDICT 26



423446 SYN HEADSET IS44|35 - IS52|42 STAINLESS

# ADDICT

## GENERAL SPARE PARTS



426251 SCO FD MOUNT ADDICT 26



424157 SCO STEM HARDWARE KIT CRESTON IC SL 25



423441 SYN STEM ST-R100-AL (handlebar clamp and steerer clamp torque)



423444 SYN SEATPOST SP-R101-CF 0MM OFF



423445 SYN SEATPOST SP-R101-CF 15MM OFF

# ADDICT

## GENERAL SPARE PARTS



423440 SYN HANDLEBAR HB-R100-AL



423439 SYN HANDLEBAR HB-R100-CF



423432 SYN REAR LIGHT CAMPBELL 20 D IL



425261 SCO SEATPOST LIGHT BLANK ADDICT RC 25

# ADDICT

## GENERAL SPARE PARTS



426255 SCO CABLE DT COVER ADDICT 26



426254 SCO DT CONTAINER ADDICT 26

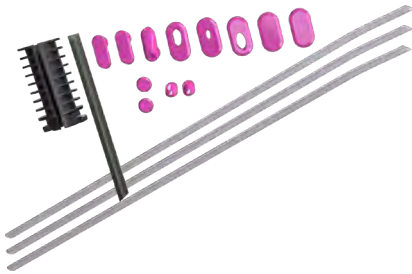

426252 SCO FINISHING KIT ADDICT 26

# MANUFACTURER'S GUARANTEE,

When purchasing a new SCOTT bicycle from an authorized SCOTT dealer, SCOTT grants a manufacturer's guarantee subject to the following provisions.

## CONDITIONS

The manufacturer's guarantee is only granted to the first-time buyer of a SCOTT bicycle who has purchased it from an authorized SCOTT dealer. The manufacturer's guarantee only applies if the bicycle is registered to the first buyer at [www.scott-sports.com](http://www.scott-sports.com) within one year of purchase.

## DURATION

The manufacturer's guarantee is granted from the date of purchase for a period of five years on bicycle frames and rear ends. The guarantee period is reduced to three years, if the SCOTT bicycle is not serviced at least once a year by an authorized SCOTT dealer. Maintenance services must be carried out in accordance with the maintenance instructions in the SCOTT manual and must be confirmed there by the stamp and signature of the authorized SCOTT dealer.

For frames and rear ends of Category 5 bicycle models and for rigid forks manufactured by SCOTT, the duration of the manufacturer's guarantee is limited to two years.

If a defect on the SCOTT bicycle is remedied within the scope of a manufacturer's guarantee or a warranty claim, the duration of the manufacturer's guarantee is not extended. The manufacturer's guarantee ends, when the first-time buyer transfers ownership of the SCOTT bicycle to a third person.

## ASSERTION

The manufacturer's guarantee is provided by SCOTT Sports SA, Route du Crochet 11, 1762 Givisiez, Switzerland. The buyer must inspect the SCOTT bicycle immediately after purchase and notify his authorized SCOTT dealer at once in writing of any obvious defects. Hidden defects must be reported immediately after their discovery. In the event of a guarantee claim, the SCOTT bicycle must be handed over to an authorized SCOTT dealer. The latter will contact SCOTT to remedy the defect. The assertion of a guarantee claim always requires the presentation of the original proof of purchase as well as the proof of maintenance service in the SCOTT manual.

Performance of SCOTT in the event of a guarantee claim

In the event of a guarantee claim, SCOTT will, at its own discretion, repair the defect or replace the defective product with a product of similar quality, whereby colour and model deviations are possible. If a repair or replacement is not possible, a purchase price refund will be made taking into account previous use. SCOTT is entitled to commission third parties to remedy the defect.

## LIMITATIONS

The manufacturer's guarantee applies exclusively to frames, swingarms and rigid forks of SCOTT bicycles. Bicycle components are excluded from this manufacturer's guarantee.

The manufacturer's guarantee does not apply to normal wear and tear, damage caused by accidents or other excessive force on the SCOTT bicycle, corrosion, improper maintenance, incorrect assembly and assembly of unsuitable components or accessories as well as cosmetic defects, for example in the varnish.

The manufacturer's guarantee does not apply to SCOTT bicycles that have been used in a rental shop.

## MISCELLANEOUS

These manufacturer's guarantee provisions apply to all SCOTT bicycles as of model year 2023. Statutory warranty rights of the buyer and guarantees of component manufacturers (Shimano, SRAM etc.) remain unaffected by this manufacturer's guarantee. The place of jurisdiction for all disputes in connection with this manufacturer's guarantee is Freiburg, Switzerland. This manufacturer's guarantee is subject to Swiss law to the exclusion of all legislation that refers to foreign law.

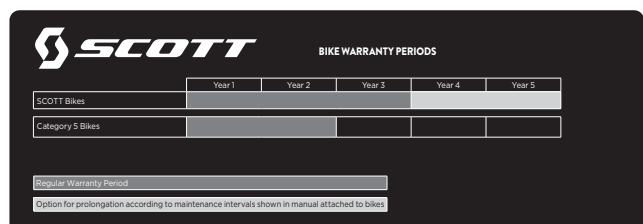

	Year 1	Year 2	Year 3	Year 4	Year 5
SCOTT Bikes					
Category 5 Bikes					

Original Warranty Period: \_\_\_\_\_  
Option for prolongation according to maintenance intervals shown in manual attached to bikes



All rights reserved  
© 2026 SCOTT Sports SA

Distribution:  
SSG (Europe) Distribution Center SA  
P.E.D. Zone C1  
Rue du Kiell 60  
6790 Aubange  
Belgium

SCOTT Sports SA  
Route du Crochet 11  
1762 Givisiez  
Switzerland

[www.scott-sports.com](http://www.scott-sports.com)|contact  
[www.scott-sports.com](http://www.scott-sports.com)



Points de collecte sur [www.quefairedemesdechets.fr](http://www.quefairedemesdechets.fr)  
Privilégiez la réparation ou le don de votre appareil !